

PUMPSET CERT. NO. : 20180802-MP5163  
 PUMP CERT. NO. : 20190411-MH63401  
 STRAINERS CERT. NO. : 20170721-MP5156

**NOTE :** This drawing and the information depicted therein is the property of Albany Pump Co. Ltd. Copies are issued in strict confidence and shall not be reproduced, copied or used as the basis for the manufacture or sale of products without prior written permission of Albany Pump Co.

**OPERATING CONDITIONS**

Fluid	Fuel Oil
Pump Capacity	0-35 GPM
Pressure	0-250 PSI
Inlet	As Required
Outlet	As Required

since 1906  
**albany**  
 pump company ltd.

**MANUFACTURING HEADQUARTER:**  
 420 Harry Walker pkwy. Newmarket,  
 Ontario Canada, L3Y 8P5  
**Sales Office:**  
 Burnaby, B.C. (Canada)  
 Buffalo, New York, (USA)  
 Phone: (905) 853-9005  
 Toll Free: 1 (888) 334-3348  
 Fax: (888) 335-3391  
 E-mail: sales@albanyump.com  
 www.albanyump.com

LAYOUT - A

DRAWING NO :  
 -----

DRAWN : VP	TAG : DUPLEX FUEL OIL PUMPSET
SHEET NO : 100	
CHECK : --	MODEL : FODUP-G-BS
SCALE : 1:4	REVISION : R0
DATE : -	

**NOTE :** All dimentions are approximate and subject to change without notice



PUMPSET CERT. NO. : 20180802-MP5163  
 PUMP CERT. NO. : 20190411-MH63401  
 STRAINERS CERT. NO. : 20170721-MP5156

**NOTE :** This drawing and the information depicted therein is the property of Albany Pump Co. Ltd. Copies are issued in strict confidence and shall not be reproduced, copied or used as the basis for the manufacture or sale of products without prior written permission of Albany Pump Co.

**OPERATING CONDITIONS**

Fluid	Fuel Oil
Pump Capacity	0-35 GPM
Pressure	0-250 PSI
Inlet	As Required
Outlet	As Required

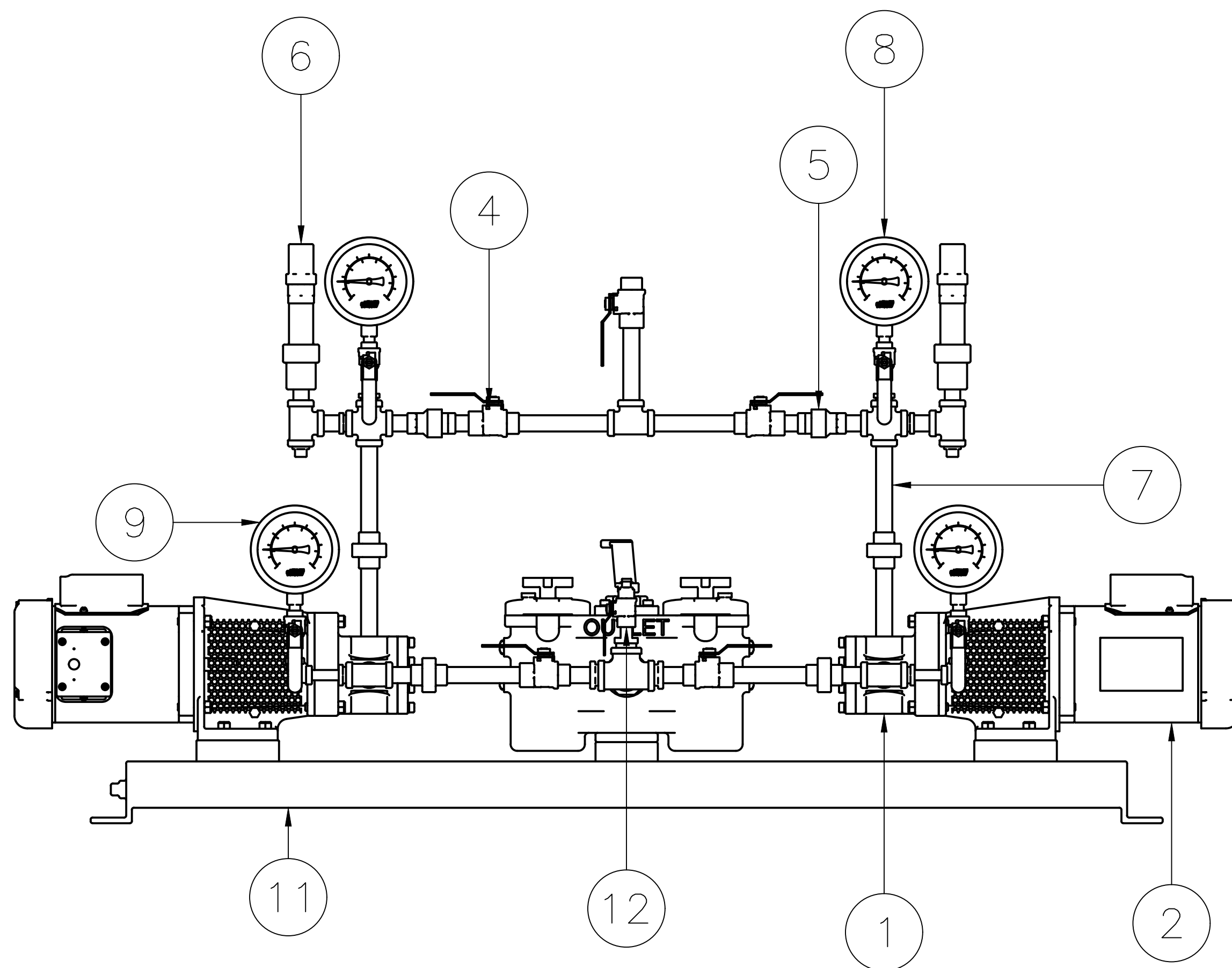

since 1906  
**albany**  
 pump company ltd.

**MANUFACTURING HEADQUARTER:**  
 420 Harry Walker pkwy. Newmarket,  
 Ontario Canada, L3Y 8P5  
**Sales Office:**  
 Burnaby, B.C. (Canada)  
 Buffalo, New York, (USA)  
 Phone: (905) 853-9005  
 Toll Free: 1 (888) 334-3348  
 Fax: (888) 335-3391  
 E-mail: sales@albanyump.com  
 www.albanyump.com

**LAYOUT - A**

DRAWING NO :  
 -----

DRAWN : VP	TAG : DUPLEX FUEL OIL PUMPSET
SHEET NO : 101	
CHECK : --	MODEL : FODUP-G-BS
SCALE : 1:4	REVISION : R0
DATE : -	



PUMPSET CERT. NO. : 20180802-MP5163  
 PUMP CERT. NO. : 20190411-MH63401  
 STRAINERS CERT. NO. : 20170721-MP5156

**NOTE :** This drawing and the information depicted therein is the property of Albany Pump Co. Ltd. Copies are issued in strict confidence and shall not be reproduced, copied or used as the basis for the manufacture or sale of products without prior written permission of Albany Pump Co.

**OPERATING CONDITIONS**

Fluid	Fuel Oil
Pump Capacity	0-35 GPM
Pressure	0-250 PSI
Inlet	As Required
Outlet	As Required

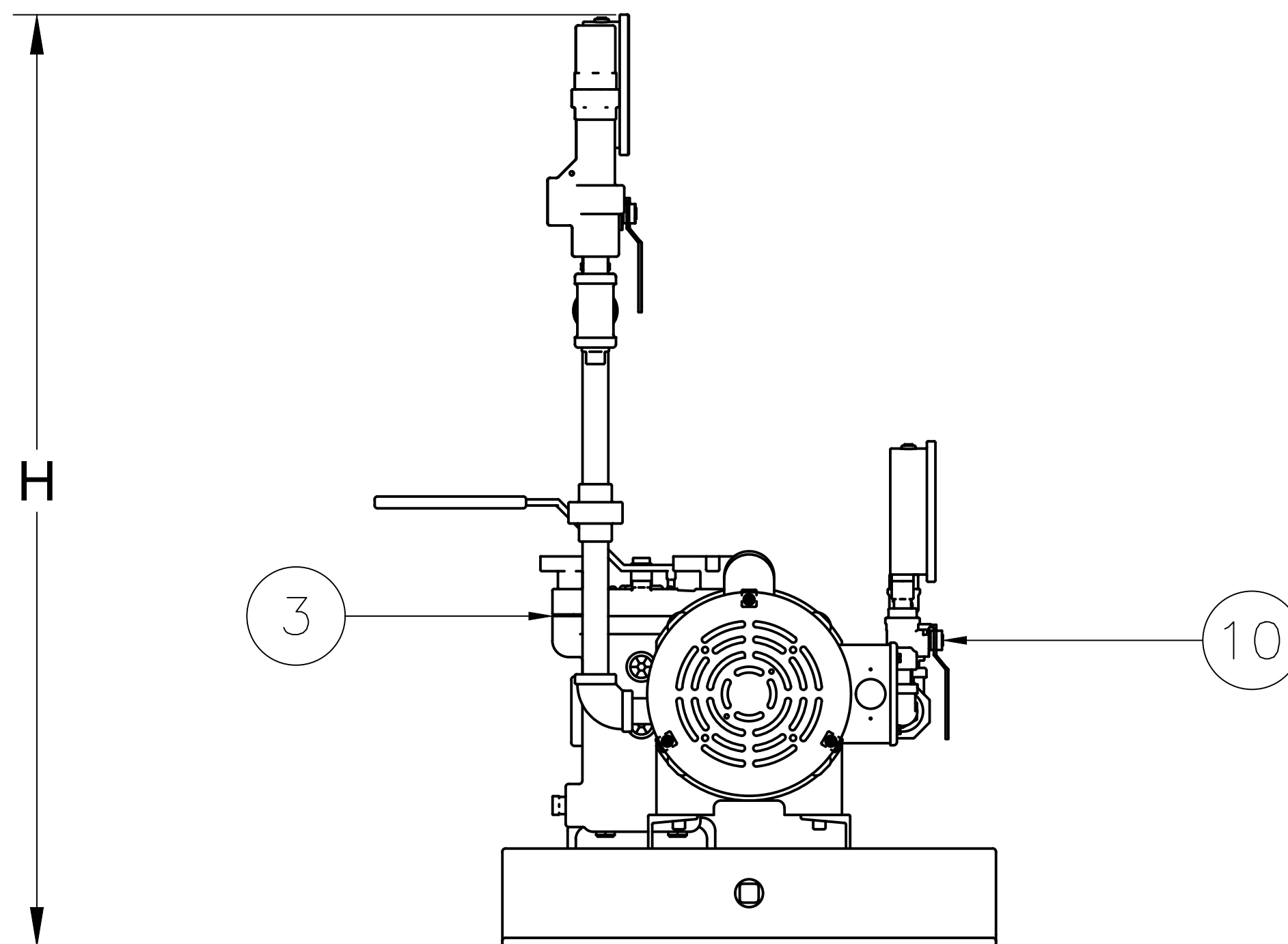

since 1906  
**albany**  
 pump company ltd.

**MANUFACTURING HEADQUARTER:**  
 420 Harry Walker pkwy. Newmarket,  
 Ontario Canada, L3Y 8P5  
**Sales Office:**  
 Burnaby, B.C. (Canada)  
 Buffalo, New York, (USA)  
 Phone: (905) 853-9005  
 Toll Free: 1 (888) 334-3348  
 Fax: (888) 335-3391  
 E-mail: sales@albanyump.com  
 www.albanyump.com

LAYOUT - A

DRAWING NO :  
 -----

DRAWN : VP	TAG : DUPLEX FUEL OIL PUMPSET
SHEET NO : 102	
CHECK : --	MODEL : FODUP-G-BS
SCALE : 1:4	REVISION : R0
DATE : -	



PUMPSET CERT. NO. : 20180802-MP5163  
 PUMP CERT. NO. : 20190411-MH63401  
 STRAINERS CERT. NO. : 20170721-MP5156

**NOTE :** This drawing and the information depicted therein is the property of Albany Pump Co. Ltd. Copies are issued in strict confidence and shall not be reproduced, copied or used as the basis for the manufacture or sale of products without prior written permission of Albany Pump Co.

**OPERATING CONDITIONS**

Fluid	Fuel Oil
Pump Capacity	0-35 GPM
Pressure	0-250 PSI
Inlet	As Required
Outlet	As Required

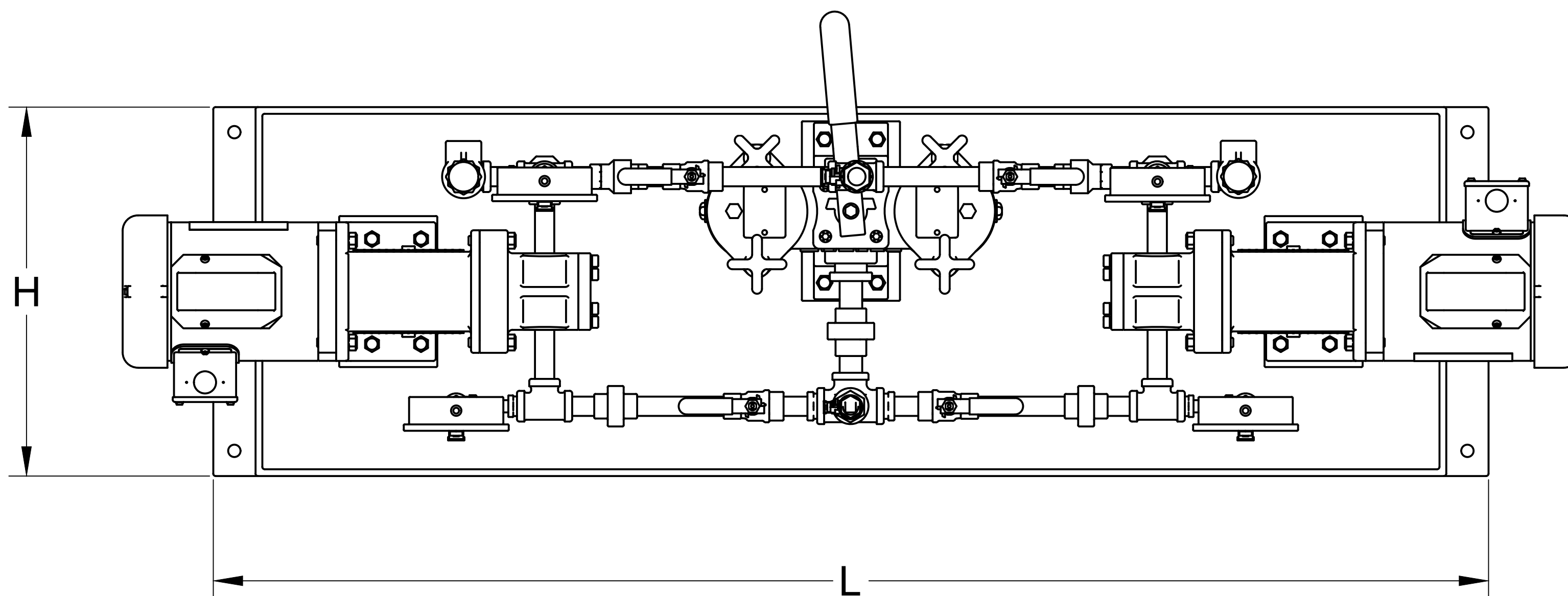

**albanypump.com** since 1906  
**albanypump company ltd.**

**MANUFACTURING HEADQUARTER:**  
 420 Harry Walker pkwy. Newmarket,  
 Ontario Canada, L3Y 8P5

**Sales Office:**  
 Burnaby, B.C. (Canada)  
 Buffalo, New York, (USA)  
 Phone: (905) 853-9005  
 Toll Free: 1 (888) 334-3348  
 Fax: (888) 335-3391  
 E-mail: sales@albanypump.com  
 www.albanypump.com

Size	Inlet	Outlet	Max L	Max H	Max W
03	.05"	.05"	52"	36"	15"
05	.75"	.75"	54"	36"	15"
10	1.00"	1.00"	60"	44"	15"
18	1.25"	1.25"	60"	44"	15"
25	1.50"	1.50"	70"	50"	15"
35	1.50"	1.50"	70"	50"	15"

LAYOUT - A

DRAWING NO :  
 -----

DRAWN : VP	TAG : DUPLEX FUEL OIL PUMPSET
SHEET NO : 103	
CHECK : --	MODEL : FODUP-G-BS
SCALE : 1:5	REVISION : R0
DATE : -	

# BILL OF MATERIAL

No	DESCRIPTION	QUANT	CERT
1	Cast Iron Helical Gear Pump, G Series, 250 PSI	2	cUL ULC/ORD-C343
2	Nema Premium Efficiency Wattsaver Motor, TEFC Enclosure	2	CSA cUL
3	Basket Type Suction Strainer, C/W 40 Mesh SS Screen	1	cUL ULC/ORD-C331
4	Two Piece Brass Ball Valve 500 PSI Pressure Rating	5	cUL ULC/ORD-C842
5	Spring Loaded In-Line Check Valve S.S Spring Tight Shut Off, 400 PSI	2	CRNREG 0C11218.5C
6	Pressure Relief Valve, Cast Iron Body, S.S. Spring	2	CRNREG OC16200-5ADD1
7	Heavy Duty SCH. 80 Piping Package	1	ANSI/ASME-B31
8	Pressure Gauge Liquid Filled, 304 Stainless Steel Case	2	CRN REG
9	Compound Vacuum Gauge, Liquid Filled, 304 Stainless Steel Case 30"-0- 30 PSI	2	CRN REG
10	Gauge Isolation valve, Two Piece Ball Valve 500 PSI Pressure Rating	4	cUL ULC/ORD-C842
11	¼" Fabricated Steel Base with 50mm Drip Lip	1	-
12	Priming Port and Valve	1	cUL ULC/ORD-C842



PUMPSET CERT. NO. : 20180802-MP5163  
 PUMP CERT. NO. : 20190411-MH63401  
 STRAINERS CERT. NO. : 20170721-MP5156

**NOTE :** This drawing and the information depicted therein is the property of Albany Pump Co. Ltd. Copies are issued in strict confidence and shall not be reproduced, copied or used as the basis for the manufacture or sale of products without prior written permission of Albany Pump Co.

### OPERATING CONDITIONS

Fluid	Fuel Oil
Pump Capacity	0-35 GPM
Pressure	0-250 PSI
Inlet	As Required
Outlet	As Required



**MANUFACTURING HEADQUARTER:**  
 420 Harry Walker pkwy. Newmarket,  
 Ontario Canada, L3Y 8P5  
**Sales Office:**  
 Burnaby, B.C. (Canada)  
 Buffalo, New York, (USA)  
 Phone: (905) 853-9005  
 Toll Free: 1 (888) 334-3348  
 Fax: (888) 335-3391  
 E-mail: sales@albanyump.com  
 www.albanyump.com

LAYOUT - A

DRAWING NO :  
 -----

DRAWN : VP	TAG : DUPLEX FUEL OIL PUMPSET
SHEET NO : 104	
CHECK : --	MODEL : FODUP-G-BS
SCALE : N/A	REVISION : R0
DATE : -	