

BRONZE CLOSE COUPLED ROTARY GEAR PUMPS

MODEL N970- 3/4" NPT PORTS

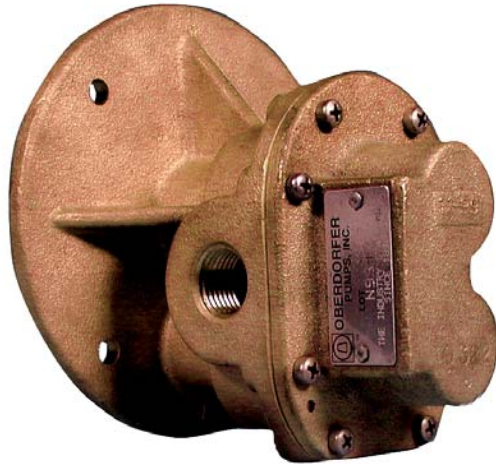

FEATURES

- Bronze Construction with Stainless Steel Shafts
- Helical gears for quiet operation
- Easy Field Assembly to Motors
- Self-Lubricating Carbon Bearings
- O-ring seal for maximum leak protection
- For clutch driven version, see N970-38

GENERAL DESCRIPTION

Pump housings and gears are made of top quality bronze, shafts are stainless steel 303. Bearings are made of high performance carbon-graphite material selected for wear resistance and long service life.

Gear pumps are positive displacement pumps. Each shaft revolution displaces a definite amount of liquid relatively unaffected by the back pressure in the discharge line. Shaft speed and flow are directly proportional.

DRIVE ARRANGEMENT

Close coupled pumps are mounted directly to the electric motor by means of a suitable adapter bracket. The pump drive shaft is connected to the motor shaft by a flexible coupling.

LIQUIDS AND TEMPERATURE

These pumps are suitable for all liquids that are compatible with bronze. Most common liquids are water, oil, and mild chemicals in the pH-range of 4 to 11. Viscous liquids require reduced shaft speeds of 1150 RPM or lower. Consult factory.

Liquids containing solids, abrasives, powders or paint pigments are definitely not recommended for gear pumps. If abrasives are unavoidable, use a very low shaft speed. The recommended liquid temperature range is 32°F to 140°F for longest pump life. If more extreme temperature conditions exist, our factory should be consulted. Freezing of water-filled pumps can cause damage and must be avoided. Oils at low temperatures are very viscous requiring a lower speed or extra power.

PERFORMANCE

Water at 70° F

1725 RPM					Pump & Motor No.	
PSI	GPM	HP Req.	HP Motor	Motor Frame	Single Phase	Three Phase
0	19.80	0.80	1	56C	N970HN26	N970HN95
20	19.30	1.00	1	56C	N970HN26	N970HN95
40	19.00	1.35	1 1/2	145TC	N970JT45	N970JT95
60	18.70	1.75	2	145TC	N970JW45	N970JW95
80	18.40	2.20	3	182TC	N970KY45	N970KY95
100	18.00	2.65	3	182TC	N970KY45	N970KY95
125*	17.70	3.00	3	182TC	N970KY45	N970KY95
150*	17.40	3.60	5	184TC	N970KX45	N970KX95

1150 RPM					Pump & Motor No.	
PSI	GPM	HP Req.	HP Motor	Motor Frame	Single Phase	Three Phase
0	12.60	0.48	1/2	56C	N970HJ46	N970HJ96
20	12.20	0.63	3/4	56C	N970HM46	N970HM96
40	11.90	0.83	1	145TC	N970JN46	N970JN96
60	11.50	1.08	1	145TC	N970JN46	N970JN96
80	11.20	1.33	1 1/2	145TC	N970JT46	N970JT96
100	10.80	1.63	2	184TC	N970KW46	N970KW96
125*	10.30	1.90	2	184TC	N970KW46	N970KW96
150*	10.00	2.20	3	213TC	N970LY46	N970LY96

*For pressures over 100 psi, the above selections are suitable for pumping fluids with lubricity (e.g. oils, polymers). Service life will decrease for fluids without lubricity (e.g. water, solvents).

SUCTION LIFT

As a general rule, the suction lift should be kept at an absolute minimum by placing the pump as close to the liquid source as possible. A gear pump in new condition can lift 20 feet of water in the suction line. A foot valve (preferably with built-in strainer) is recommended at the beginning of the suction line. For a first start-up, the pump should be primed to avoid dry running. Minimum size of the suction pipe is the size of the pump inlet port. For longer suction lines (over 3 feet), or for viscous liquids, the pipe size should be at least one size or two sizes larger than the pump inlet port.

ROTATION AND RELIEF VALVE

The relief valve is not intended to be a metering or flow control device. Its main purpose is to function as a discharge pressure relief when spring tension is exceeded by the discharge pressure. Overheating can occur within 5-10 minutes if the discharge line is completely shut off for extended periods.

Unless otherwise specified, the pump motor unit is supplied by the factory for shaft rotation clockwise from shaft end. Reversing the motor rotation will reverse the "in" and "out" ports and also requires changing the relief valve location. The relief valve is always on the discharge side in this pump series. The factory pressure setting is 50 PSIG. To increase pressure, turn the relief valve adjusting screw in a clockwise direction.

To reverse single phase motors, find instructions on the inside of the junction box cover or on the name plate of the motor.

Three phase motors are not wired for any particular rotation. They can be reversed by interchanging any two (2) wires of the three (3) wire leads.

BRONZE CLOSE COUPLED ROTARY GEAR PUMPS

EXPLODED VIEW AND PARTS LIST

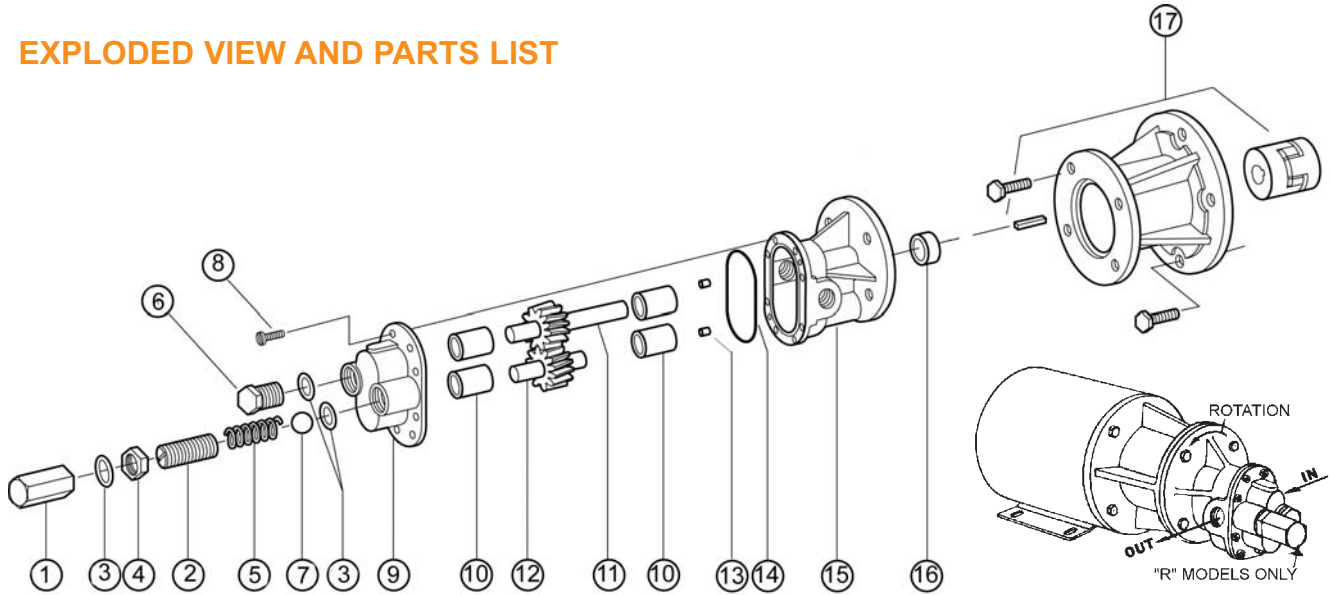

Pump No.	1	2	3	4	5	6	7	8	9	10 ¹	11 ¹	12 ¹	13	14 ¹	15	16 ^{1,2}	17
	Bypass Nut	Adj. Screw	Fiber Washer	Locknut	Spring	Plugnut	Ball	Screw	Cover	Bearing	Drive Gear Assy.	Idle Gear Assy.	Dowel Pin	O-Ring	Body	Lipseal	Adapter Kits
	1 Req'd	1 Req'd	3 Req'd	1 Req'd	1 Req'd	1 Req'd	1 Req'd	8 Req'd	1 Req'd	4 Req'd	1 Req'd	1 Req'd	2 Req'd	1 Req'd	1 Req'd	1 Req'd	
N970	---	---	---	---	---	---	---	5385	9326NN5N	5091	32958	32959	8885	9797-045	9328NE2N	5463	See
N970R	5276	5275	6965	1642	5277	5278	6217	5385	9327NN5B	5091	32958	32959	8885	9797-045	9328NE2N	5463	Below

¹ Repair kits contain items 10, 11, 12, 14 & 16. Repair kit for N970(R) is 12085.

² Part # 5463 is standard Buna N, part #9997 is Viton(R)*-Teflon(R)*.

Adapter Kits

Adapter Kit	Part Number	Description
H	11299	56C Frame
J	11300	143TC/145TC
K	11301	182TC/184TC
L	11302	213TC/215TC

Variations

Pump Model	16 ^{1,2} Lipseal	Description	Repair Kit
N970S15	9997	Viton(R)*-Teflon(R)*	12111
N970RS15	9997	Viton(R)*-Teflon(R)*	12111

Motor/Adapter Kit Dimensions (see below)

Model	Motor Frame	"A"	"B"	"C"
N970(R)H	56C	8.68	6.56	3.50
N970(R)J	143TC/145TC	8.68	6.56	3.50
N970(R)K	182TC/184TC	9.50	7.38	4.50
N970(R)L	213TC/215TC	9.50	7.38	5.25

DIMENSIONS

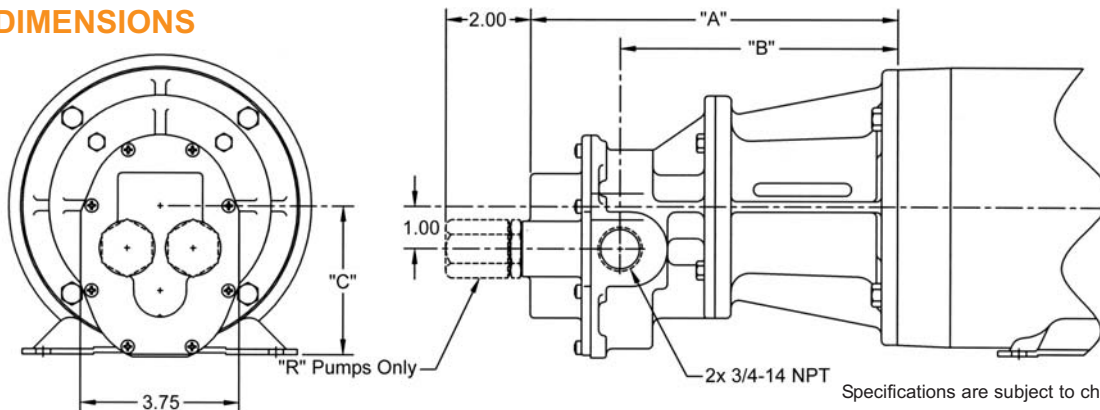

*Viton(R) or equivalent FKM will be used. Viton(R) is a trademark of DuPont Dow Elastomers.
Teflon(R) or equivalent PTFE will be used. Teflon(R) is a trademark of DuPont.