

BRONZE CLOSE COUPLED ROTARY GEAR PUMPS

**MODEL
 N993
 SERIES**

MODEL N993 - 1/2" NPT PORTS STANDARD



Pump	Description
N993	Standard pump with 1/2" ports
N993R	Pump with 1/2" ports & relief valve
N993S5	Pump with Viton®* lip seal
N993RS5	Pump with Viton®)* lip seal & relief valve

3/8" NPT Ports Available, add "-03" suffix

FEATURES

- Rugged corrosion resistant bronze construction
- Compact close-coupled design
- Stainless steel shafts
- Durable bronze helical gears provide quiet operation
- Process lubricated carbon graphite bearings
- O-ring cover seal for maximum leak protection
- Buna Lip Seal -standard
- Easy field assembly to a variety of motor frames
 - For compact AC motor pump units - see Close Coupled Bronze Adapterless Rotary Gear Pumps
 - For Danfoss hydraulic motor driven pump units - see adapter 9960
- For bronze pedestal pumps and mechanical seal styles - see model N3000
- For close-coupled ductile iron pumps - see model C993

GENERAL DESCRIPTION

Pump housings and gears are made of top quality bronze, shafts are 303 stainless steel. Bearings are designed of high performance carbon-graphite material selected for wear resistance and long service life.

Gear pumps are positive displacement pumps. Each shaft revolution displaces a definite amount of liquid relatively unaffected by the back pressure in the discharge line. Shaft speed and flow are directly proportional. Recommended pressure limits are 100 PSI for water and non-lubricants, 150 PSI for oil and other lubricants. The maximum shaft speed is 1750 RPM.

SHAFT SEALS

Close coupled gear pumps are normally supplied with a Buna N lip seal. A lip seal made of Viton(R)* is available as an option. For a Viton(R)* Seal, add S5 to the pump model number.

PERFORMANCE

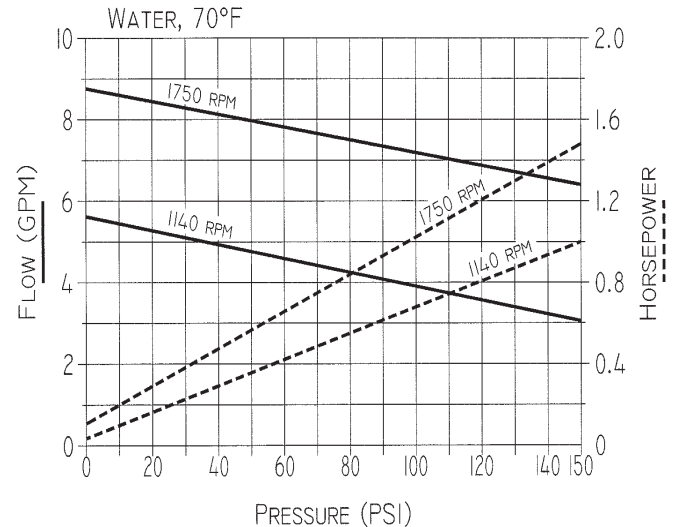

LIQUIDS AND TEMPERATURE

These pumps are suitable for all liquids that are compatible with bronze. Most common liquids are water, oil, and mild chemicals in the pH range of 4 to 11. Viscous liquids require reduced shaft speeds of 1140 RPM or lower. (Consult factory.)

Liquids containing solids, abrasives, powders, or paint pigments are definitely not recommended for gear pumps. If abrasives are unavoidable, use a very low shaft speed.

The recommended liquid temperature range is from 32° F to 140° F for best pump life. If more extreme temperature conditions exist, factory should be consulted. Freezing of water-filled pumps can cause damage and must be avoided. Oils at low temperatures are very viscous requiring a lower speed or extra power.

SUCTION LIFT

As a general rule, the suction lift should be kept at an absolute minimum by placing the pump as close to the liquid source as possible. A gear pump in new condition can lift 20 feet of water in the suction line. A foot valve (preferably with built-in strainer) is recommended at the beginning of the suction line. For a first start-up, the pump should be primed to avoid dry running. Minimum size of the suction pipe is the size of the pump inlet port. For longer suction lines (over 3 feet) or for viscous liquids, the pipe should be at least one size or two sizes larger than the pump inlet port.

ROTATION AND RELIEF VALVE

If the discharge line contains any throttling devices such as a shut-off valve, a spray nozzle or other restrictive device, it is necessary to have a relief valve in the system which returns the liquid to the suction side or to the tank. The relief valve is also available as part of the pump itself (R-model pumps). However, built-in relief valves are only good for intermittent service. If used continuously, the pump will overheat. A built-in relief valve is strictly a safety device against overpressure. It will not work successfully as a pressure or flow control device. For this purpose a separate relief valve in the pressure line must be used.

Unless otherwise specified, the pump motor unit is supplied by the factory for shaft rotation counterclockwise from pump shaft end. Reversing motor will reverse "in and "out" ports and also requires changing relief valve location. The relief valve is always on the inlet side of this pump series. The factory pressure setting is 50 PSIG. To increase pressure, turn the relief valve adjusting screw in a clockwise direction.

EXPLODED VIEW AND PARTS LIST

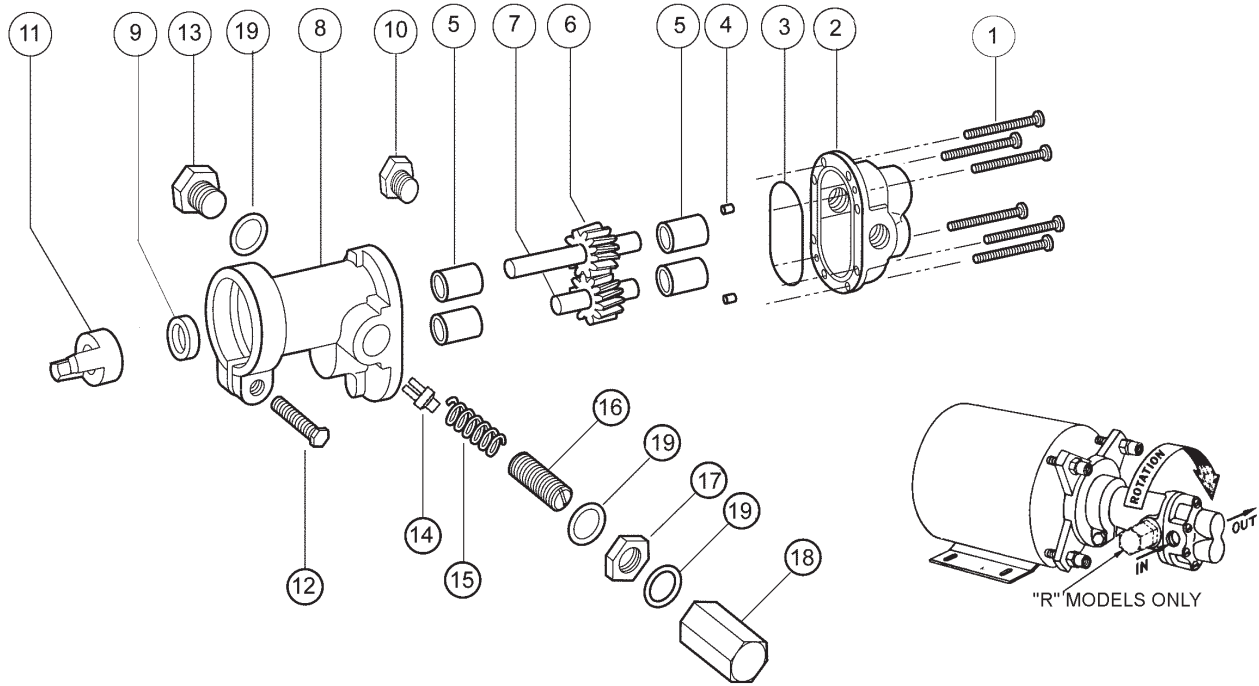

Pump No.	1	2	3 ²	4	5 ²	6 ²	7 ²	8	9 ^{1,2}	10	11	12	13	14	15	16	17	18	19
	Screw	Body	O-Ring	Dowel Pin	Bearing	Drive Gear Assy.	Idle Gear Assy.	Cover	Lip Seal	Cap Plug	Coupling Half	Screw	Plug Nut	Poppet	Spring	Adj. Screw	Locknut	Bypass Nut	Fiber Washer
	6 Req'd	1 Req'd	1 Req'd	2 Req'd	1 Req'd	1 Req'd	1 Req'd	1 Req'd	1 Req'd	1 Req'd	1 Req'd	1 Req'd	1 Req'd	1 Req'd	1 Req'd	1 Req'd	1 Req'd	1 Req'd	3 Req'd
N993	9837-20	9307ND5N	9797-038	8885	5024	32950	32937	9308NN2N	5007	9346	5604	5595	---	---	---	---	---	---	---
N993R	9837-20	9307ND5N	9797-038	8885	5024	32950	32937	9308NN3B	5007	9346	5604	5595	1838	6535	6301	5237	5240	5239	6533

¹Seal # 5007 is Standard Buna N, # 7580 is Viton®-Teflon®*
²Repair Kits contain items 3, 5, 6, 7 & 9. Repair Kit for N993® is #12070.

VARIATIONS

DIMENSIONS

Pump No.	g ^{1,2}	
	Lip Seal	Repair Kit ²
N993S5	7580	12101
N993RS5	7580	12101

Adapter Kit	Kit Number	Description
M	10562	48 Frame
N	10816	56 Frame
P	11722	S56 Frame
Q	11331	56C Frame (to ¼ HP)
C	11331H	56C Frame (above ¼ HP)
F	11332	IEC71
---	---	Adapterless- Modified 48

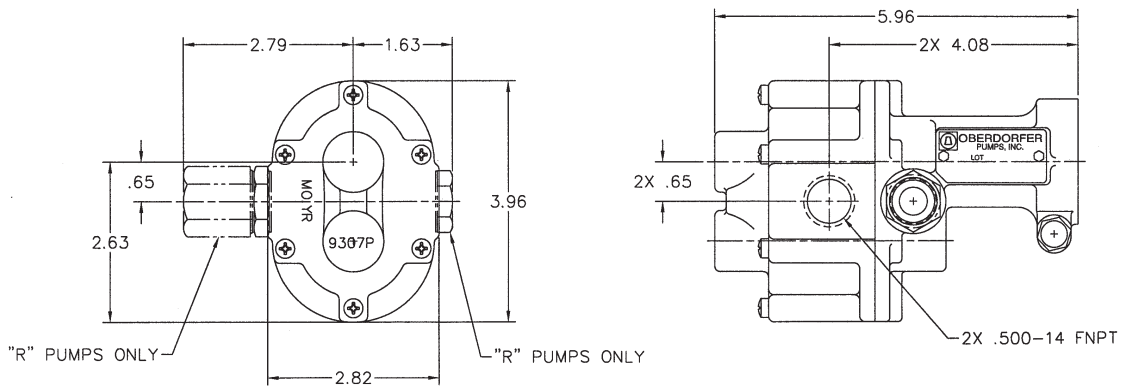

Specifications are subject to change without no

*Viton® or equivalent FKM will be used.
 Viton® is a registered trademark of DuPont Dow Elastomers.
 *Teflon® or equivalent PTFE will be used. Teflon® is a registered trademark of DuPont.