

V-SERIES VALVES

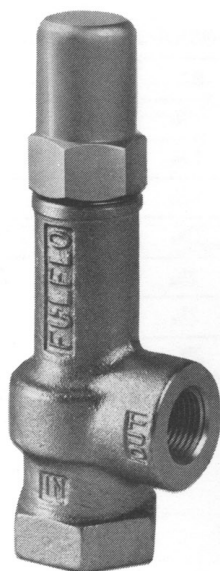

Standard
with Screw
Connections

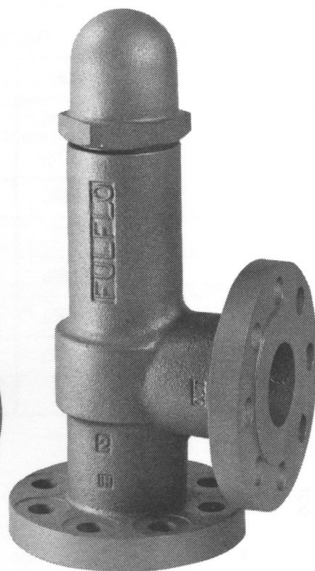

Standard
with Flange
Connections



Stainless Steel
with Screw
Connections



Handwheel
with Screw
Connections

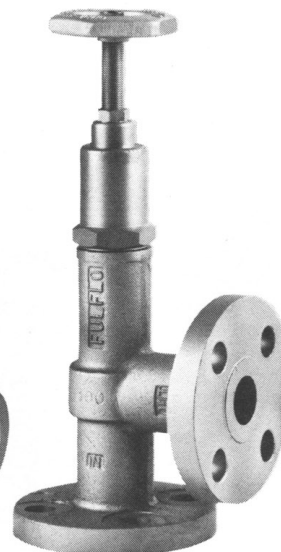

Handwheel
with Flange
Connections

APPLICATION

The Fulflo "V" Series range in size from 1/4" through 2" and operate efficiently with liquids of any viscosity at pressures from 2 to 1000 P.S.I. The "V" series valves are available in flange or screw type...cartridge or handwheel in a choice of brass, cast iron, steel and stainless steel.

Widely used in a variety of applications, the "V" series valves are ideally suited in hydraulic and lubricating systems for load regulation and system protection. Special trim or packings are available for use with fire resisting fluids and other liquids of this type. Unusual applications and special requirements should be referred to our engineering staff for recommendation.

INSTALLATION

Fulflo valves can be mounted in any position. A tee may be inserted in the pump discharge line to mount the valve. The correct size of valve should be installed, preferably matching the pump discharge line. Screw the valve into the nipple in the tee, or in the case of the flange style, bolt the valve to the companion flange screwed into the nipple. When the valve is used for frequent bypassing of oil pressure, its outlet

should be piped back to the tank. Care must be taken to have the discharge well below the oil level in the tank to prevent air entrainment and erratic operation.

Only if the valve is used as safety or overload relief and operates infrequently may its discharge be piped back into the pump suction line. Frequent or continuous operation under these conditions will cause excessive heating of the oil and possible damage.

SETTING VALVES

Valves may be set with a hydraulic hand pump for cracking pressure. If a test stand is available, valve should be connected to the discharge header with the pump bypass open, and the bypass gradually closed until the desired pressure registers on the gauge. Adjust valve adjusting screw until valve slightly bleeds at the set bypass pressure and lock adjusting screw.

Fulflo valves are not designed to be positive shut-off, and will pass a minimal amount of leakage before the set pressure. If a valve is required to bypass a given amount of fluid at a given pressure, a test stand

having a flow meter in the pump discharge line must be available. With a valve adjusted for cracking pressure as above, continue closing bypass until the required flow registers on the flow meter and observe pressure. Readjust pressure, if necessary, to obtain desired pressure at desired flow.

MAINTENANCE

Fulflo valves provide reliable “chatter-free” operation when the system is free of abrasives and foreign matter. Continuous filtration of the liquid used is strongly recommended.

TYPICAL DISASSEMBLY OF STANDARD TYPE VALVE

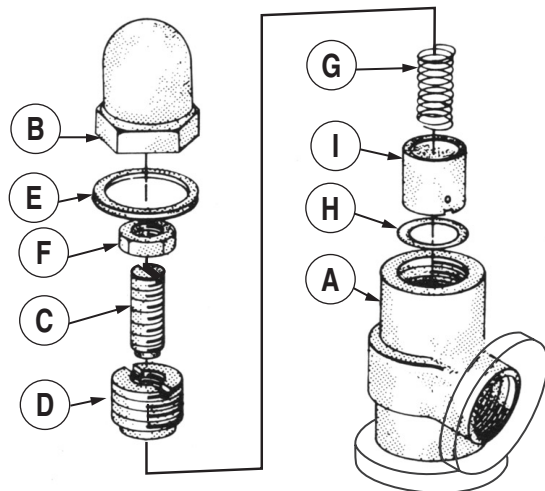

To dismantle valve for inspection or cleaning:

1. Remove cap “B”
2. Remove O-Ring “E”
3. Remove lock nut “F”
4. Remove adjusting screw “C”
5. Remove retainer “D”
6. Remove spring “G”
7. Remove piston “I”
8. Remove stop ring “H” (Not Recommended)
(Special tooling is required to install new stop ring.)

Inspect valve bore and piston for wear and scoring. Replace broken or damaged parts. Clean all parts thoroughly and re-assemble by reversing the above procedure.

TYPICAL DISASSEMBLY OF HANDWHEEL TYPE VALVE

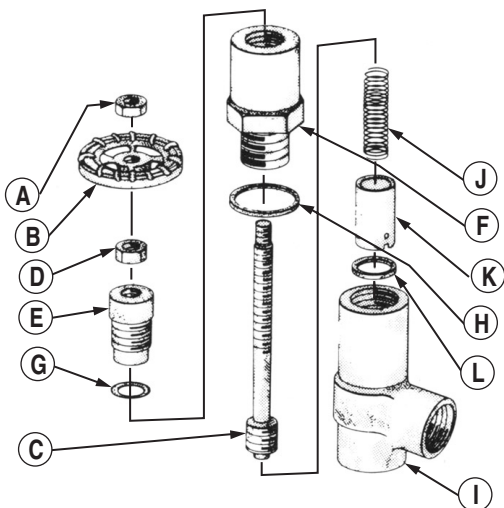

To dismantle the valve for inspection or cleaning:

1. Release spring tension by backing off handwheel as far as it will go.
2. Remove lock nut “A” or set screw and take off handwheel “B”
3. Remove lock nut “D”
4. Unscrew and remove gland “E”
5. Unscrew and remove bonnet “F”
6. Remove O-Ring “H”
7. Remove adjusting screw “C” (turn clockwise and pull out from bottom of bonnet “F”)
8. Remove O-ring packing “G”
9. Remove spring “J”
10. Remove piston “K”
11. Remove stop ring “L” (Not Recommended)
(Special tooling is required to install new stop ring.)

Inspect valve bore and piston for wear or scoring. Replace broken or damaged parts. Clean all parts thoroughly and re-assemble by reversing the above procedure.

ASSEMBLY NUMBER IDENTIFICATION CHART

Symbol No.	Designation	Code	Description
1	Style	None H	Standard Model Handwheel Model
2	Series	V	
3	Material	J B S SS	Cast iron Brass Steel 316 Stainless Steel
4	Connections	None F	Screw Connections Flange Connections 300# Flange Class Standard (250# Flange Class - Cast Iron Standard)
5	Size	-1 -2 -3 -4 -5 -6 -7 -8	1/4" 3/8" 1/2" 3/4" 1" 1 1/4" 1 1/2" 2"
6,7,8	ASA Flange Rating	None -150 -600	300# Flange Standard (no designation required)
9	Flange Style 150# & 600# Only	A B C D	Raised Face, Staggered Bolt Centers (standard on all Flange rating) Smooth Face, Staggered Bolt Centers Raised Face, Bolts on Valve Centerline Smooth Face, Bolts on Valve Centerline
10	O-Ring Material	R RV RS RT RA	Buna O-Ring Cap Seal (standard) Viton O-Ring Cap Seal Silicone O-Ring Cap Seal Teflon O-Ring Cap Seal (standard on VSS Series) Atlas O-Ring Cap Seal
11	Options	SP P	Steel Parts (used on cast iron only) Panel Mount on Handwheel Series
12	Piston Material	/HS /SS /3SS	Hardened Steel 416 Stainless Steel 303 Stainless Steel
13	Spring	AS US WS XS YS ZS	
14	Setting		Desired Pressure Setting

EXAMPLES:

VJ-1RVSP/HS/WS

V	J	-1	RV	SP	/HS	WS
Series	Cast Iron	1/4"	Viton O-Ring	Steel Parts	H.S. Piston	WS Spring

VJF-5R/HS/WS

V	J	F	-5	R	/HS	WS
Series	Cast Iron	Flanged	1"	Buna O-Ring	H.S. Piston	WS Spring

VJF-5-150AR/HS/WS

V	J	F	-5	-150	A	R	/HS	WS
Series	Cast Iron	Flanged	1"	Rating	Style	Buna O-Ring	H.S. Piston	WS Spring

NOTE: Stainless steel pistons are supplied on brass valves, unless hardened steel is specified. Hardened steel pistons are supplied on cast iron or steel unless stainless steel is specified. Buna O-Rings are supplied as standard unless other material is specified.

STANDARD PRESSURE RANGE CHART

Valve Pipe Size	Valve Flange Size	SPRING PRESSURE AND IDENTIFICATION NO.															
		BLACK-AS		RED-US		GREEN-WS		YELLOW-XS		WHITE-YS		BLUE-ZS		PURPLE-TS		BROWN-RS	
		Low	High	Low	High	Low	High	Low	High	Low	High	Low	High	Low	High	Low	High
1/4"		3	15	7	35	30	100	60	175	150	350	300	500	400	600	550	750
3/8"		3	15	7	35	30	100	60	175	150	350	300	500	400	600	550	750
1/2"		3	15	7	35	30	100	60	175	150	350	300	500	400	600	550	750
3/4"		3	15	7	35	30	100	60	175	150	350	300	500				
1"	1"	3	15	7	35	30	100	60	175	150	350	300	500				
1 1/4"	1 1/4"	3	15	7	35	30	100	60	175	150	350	300	500				
1 1/2"	1 1/2"	3	15	7	35	30	100	60	175	150	350	300	500				
2"	2"	3	15	7	35	30	100	60	175	150	350	250	600				

DIMENSIONS

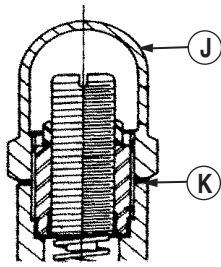

CAP
(GASKET SEAL)

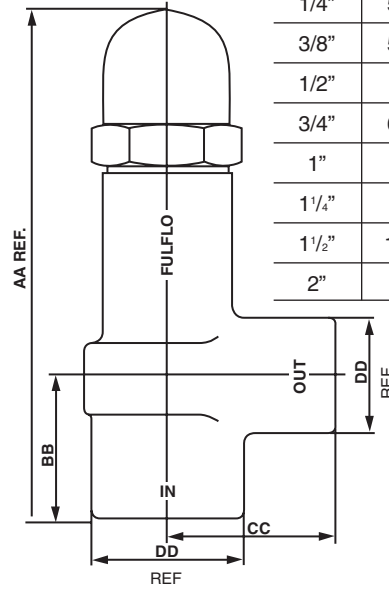
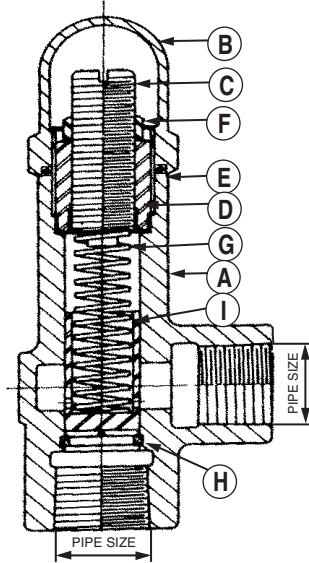

Valve Size	DIMENSIONS IN INCHES			
	AA	BB	CC	DD
1/4"	5 ¹¹ / ₃₂	1 ¹¹ / ₃₂	1 ¹¹ / ₃₂	1 ³ / ₈
3/8"	5 ¹¹ / ₃₂	1 ¹¹ / ₃₂	1 ¹¹ / ₃₂	1 ³ / ₈
1/2"	6 ³ / ₁₆	1 ¹¹ / ₁₆	1 ⁷ / ₁₆	1 ⁷ / ₁₆
3/4"	6 ¹⁵ / ₁₆	1 ¹⁵ / ₁₆	1 ¹³ / ₁₆	1 ¹¹ / ₁₆
1"	8 ⁷ / ₃₂	2 ⁹ / ₃₂	2 ⁹ / ₃₂	2 ¹ / ₁₆
1 1/4"	9 ⁹ / ₁₆	2 ⁹ / ₁₆	2 ⁹ / ₁₆	2 ¹ / ₂
1 1/2"	11 ¹ / ₁₆	2 ¹¹ / ₁₆	2 ¹¹ / ₁₆	2 ⁷ / ₈
2"	13	3	3	3 ¹ / ₄

PARTS LIST

SYM.	NAME	MODEL	VALVE SIZE							
			1/4"	3/8"	1/2"	3/4"	1"	1 1/4"	1 1/2"	2"
A	BODY	VJ, VJ-SP VB VS VSS	100 100-B 100-S 100-SS	200 200-B 200-S 200-SS	300 300-B 300-S 300-SS	400 400-B 400-S 400-SS	500 500-B 500-S 500-SS	600 600-B 600-S 600-SS	700 700-B 700-S 700-SS	800 800-B 800-S 800-SS
B	CAP (O-RING SEAL)	VJ, VJ-SP VB VS VSS	201-SR 201-BR 201-SR 201-SSR	201-SR 201-BR 201-SR 201-SSR	301-SR 301-BR 301-SR 301-SSR	401-R 401-BR 401-SR 401-SSR	501-R 501-BR 501-SR 501-SSR	601-R 601-BR 601-SR 601-SSR	701-R 701-BR 701-SR 701-SSR	801-R 801-BR 801-SR 801-SSR
C	ADJUSTING SCREW	VJ, VB VS, VJ-SP VSS	202-B 202-S 202-SS	202-B 202-S 202-SS	302-B 302-S 302-SS	402-B 402-S 402-SS	502-B 502-S 502-SS	602-B 602-S 602-SS	702-B 702-S 702-SS	802-B 802-S 802-SS
D	RETAINER	VJ, VB VS, VJ-SP VSS	203-B 203-S 203-SS	203-B 203-S 203-SS	303-B 303-S 303-SS	403-B 403-S 403-SS	503-B 503-S 503-SS	603-B 603-S 603-SS	703-B 703-S 703-SS	803-B 803-S 803-SS
E	O-RING †	VJ, VJ-SP, VB, VS VSS	204-* 204-RT	204-* 204-RT	304-* 304-RT	404-* 404-RT	504-* 504-RT	604-* 604-RT	704-* 704-RT	804-* 804-RT
F	LOCK NUT	VJ, VJ-SP, VB, VS VSS	205-S 205-SS	205-S 205-SS	305-S 305-SS	405-S 405-SS	505-S 505-SS	605-S 605-SS	705-S 705-SS	805-S 805-SS
G	SPRING †	ALL MODELS	207-**	207-**	307-**	407-**	507-**	607-**	707-**	807-**
H	STOP RING	VJ, VB VS, VJ-SP VSS	208-B 208-S 208-SS	208-B 208-S 208-SS	308-B 308-S 308-SS	408-B 408-S 408-SS	508-B 508-S 508-SS	608-B 608-S 608-SS	708-B 708-S 708-SS	808-B 808-S 808-SS
I	PISTON †	HARDENED STEEL 416 STAINLESS STEEL 303 STAINLESS STEEL	206 206-A 206-SS	206 206-A 206-SS	306 306-A 306-SS	406 406-A 406-SS	506 506-A 506-SS	606 606-A 606-SS	706 706-A 706-SS	806 806-A 806-SS
J	CAP (GASKET SEAL)	VJ, VJ-SP VB VS	201-S 201-B 201-S	201-S 201-B 201-S	301-S 301-B 301-S	401 401-B 401-S	501 501-B 501-S	601 601-B 601-S	701 701-B 701-S	801 801-B 801-S
K	GASKET †	VJ, VB VS, VJ-SP	204 204-S	204 204-S	304 304-S	404 404-S	504 504-S	604 604-S	704 704-S	804 804-S

* See o-ring selection chart

** See spring pressure chart

† Recommended spare parts

DIMENSIONS

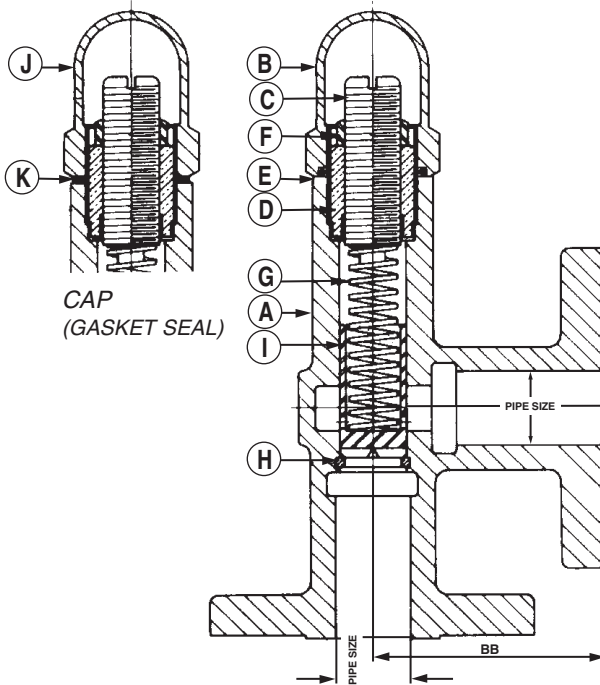

DIMENSIONS IN INCHES

Valve Size	AA	BB
1"	9 ¹ / ₂ "	3 ¹ / ₂ "
1 ¹ / ₄ "	10 ⁹ / ₁₆ "	3 ³ / ₄ "
1 ¹ / ₂ "	12 ⁷ / ₁₆ "	4 ¹ / ₁₆ "
2"	14 ⁹ / ₁₆ "	4 ⁹ / ₁₆ "

Note: Dimensions reflect 150# and 300# only

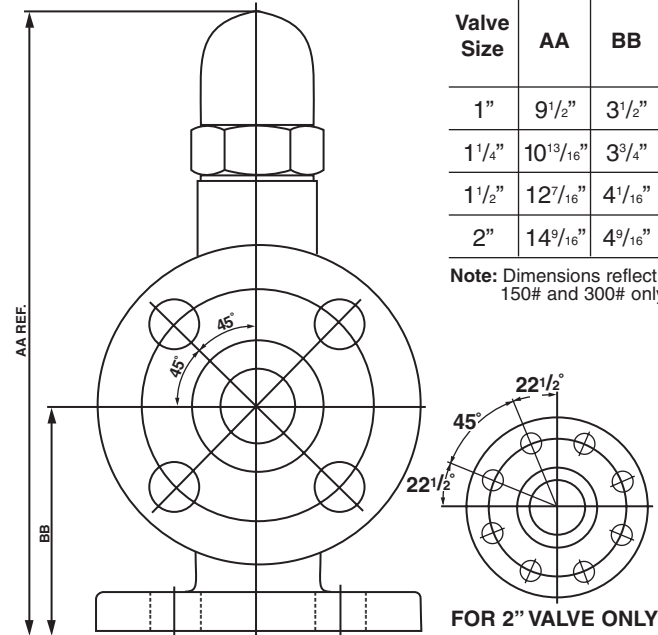

FOR 2" VALVE ONLY

PARTS LIST

SYM.	NAME	MODEL	VALVE SIZE			
			1"	1 ¹ / ₄ "	1 ¹ / ₂ "	2"
A	BODY	VJF, VJF-SP VBF VSF VSSF	500-F 500-BF 500-SF 500-SSF	600-F 600-BF 600-SF 600-SSF	700-F 700-BF 700-SF 700-SSF	800-F 800-BF 800-SF 800-SSF
B	CAP (O-RING SEAL)	VJF, VJF-SP VBF VSF VSSF	501-R 501-BR 501-SR 501-SSR	601-R 601-BR 601-SR 601-SSR	701-R 701-BR 701-SR 701-SSR	801-R 801-BR 801-SR 801-SSR
C	ADJUSTING SCREW	VJF, VBF VSF, VJF-SP VSSF	502-B 502-S 502-SS	602-B 602-S 602-SS	702-B 702-S 702-SS	802-B 802-S 802-SS
D	RETAINER	VJF, VBF VSF, VJF-SP VSSF	503-B 503-S 503-SS	603-B 603-S 603-SS	703-B 703-S 703-SS	803-B 803-S 803-SS
E	O-RING †	VJF, VJF-SP VBF, VSF VSSF	504* 504-* 504-RT	604* 604-* 604-RT	704* 704-* 704-RT	804* 804-* 804-RT
F	LOCK NUT	VJF, VJF-SP VBF, VSF VSSF	505-S 505-S 505-SS	605-S 605-S 605-SS	705-S 705-S 705-SS	805-S 805-S 805-SS
G	SPRING †	ALL MODELS	507-**	607-**	707-**	807-**
H	STOP RING	VJF, VBF VJF-SP, VSF VSSF	508-B 508-S 508-SS	608-B 608-S 608-SS	708-B 708-S 708-SS	808-B 808-S 808-SS
I	PISTON †	HARDENED STEEL 416 STAINLESS STEEL 303 STAINLESS STEEL	506 506-A 506-SS	606 606-A 606-SS	706 706-A 706-SS	806 806-A 806-SS
J	CAP (GASKET SEAL)	VJF, VJF-SP VBF VSF	501 501-B 501-S	601 601-B 601-S	701 701-B 701-S	801 801-B 801-S
K	GASKET †	VJF, VBF VJF-SP, VSF	504 504-S	604 604-S	704 704-S	804 804-S

* See o-ring selection chart

** See spring pressure chart

† Recommended spare parts

DIMENSIONS

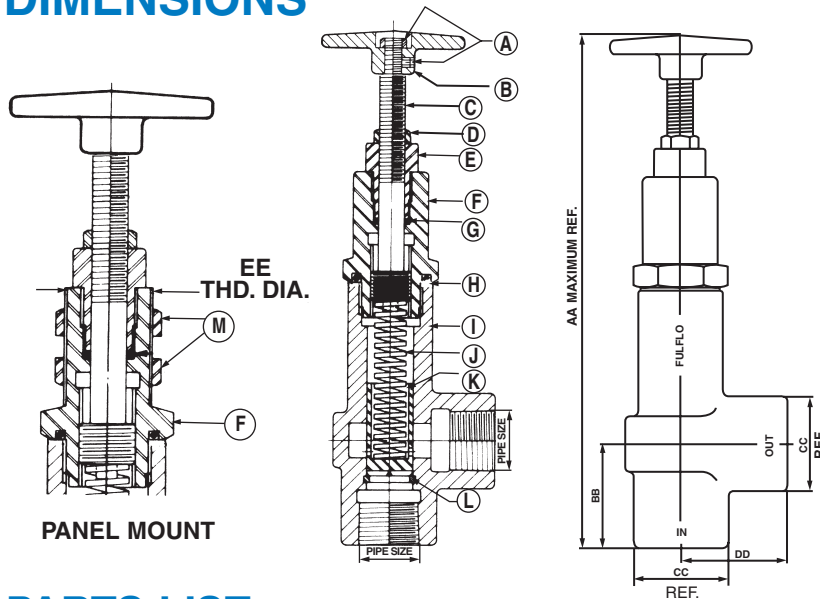

Valve Size	DIMENSIONS IN INCHES				
	AA	BB	CC	DD	EE
1/4"	8 ¹ / ₈	1 ¹¹ / ₃₂	1 ³ / ₁₆	1 ³ / ₈	7/8
3/8"	8 ¹ / ₈	1 ¹¹ / ₃₂	1 ³ / ₁₆	1 ³ / ₈	7/8
1/2"	9 ⁵ / ₈	1 ¹¹ / ₁₆	1 ⁷ / ₁₆	1 ⁷ / ₁₆	1 ¹ / ₈
3/4"	9 ³ / ₁₆	1 ¹⁵ / ₁₆	1 ¹¹ / ₁₆	1 ¹³ / ₁₆	1 ³ / ₈
1"	12 ⁷ / ₁₆	2 ⁹ / ₃₂	2 ¹ / ₁₆	2 ⁹ / ₃₂	1 ³ / ₈
1 ¹ / ₄ "	13 ⁷ / ₁₆	2 ⁹ / ₁₆	2 ¹ / ₂	2 ⁹ / ₁₆	1 ⁵ / ₈
1 ¹ / ₂ "	17 ¹ / ₁₆	2 ¹¹ / ₁₆	2 ⁷ / ₈	2 ¹¹ / ₁₆	2 ¹ / ₄
2"	17 ¹ / ₁₆	3	3 ³ / ₈	3	2 ¹ / ₄

PARTS LIST

SYM.	NAME	MODEL	VALVE SIZE							
			1/4"	3/8"	1/2"	3/4"	1"	1 ¹ / ₄ "	1 ¹ / ₂ "	2"
A	LOCK NUT OR SET SCREW	ALL MODELS	1/4"-20 COMM.	1/4"-20 COMM.	1/4"-20 COMM.	205-S	205-S	1/4"-20 COMM.	1/4"-20 COMM.	1/4"-20 COMM.
B	HANDWHEEL	ALL MODELS	229	229	229	429	429	629	629	629
C	ADJUSTING SCREW	HVJ(P), HVS(P) HVB(P) HVSS(P)	222-S 222-B 222-SS	222-S 222-B 222-SS	322-S 322-B 322-SS	422-S 422-B 422-SS	522-S 522-B 522-SS	622-S 622-B 622-SS	722-S 722-B 722-SS	822-S 822-B 822-SS
D	LOCK NUT	HVJ(P), HVS(P) HVB(P) HVSS(P) only	205-S 205-S 205-SS	205-S 205-S 205-SS	205-S 205-S 205-SS	305-S 305-S 305-SS	305-S 305-S 305-SS	655-S 655-S 655-SS	655-S 655-S 655-SS	655-S 655-S 655-SS
E	GLAND	HVJ(P), HVS(P) HVB(P) HVSS(P)	225-S 225-B 225-SS	225-S 225-B 225-SS	325-S 325-B 325-SS	525-S 525-B 525-SS	525-S 525-B 525-SS	625-S 625-B 625-SS	725-S 725-B 725-SS	825-S 825-B 825-SS
F	BONNET	HVJ, HVS HVB HVSS HVJP, HVSP HVBP HVSSP	223-SR 223-BR 223-SSR	223-SR 223-BR 223-SSR	323-SR 323-BR 323-SSR	423-SR 423-BR 423-SSR	523-SR 523-BR 523-SSR	623-SR 623-BR 623-SSR	723-SR 723-BR 723-SSR	823-SR 823-BR 823-SSR
G	O-RING †	HVJ(P), HVS(P) HVB(P) HVSS(P) only	224* 224* 224-RT	224* 224* 224-RT	224* 224* 224-RT	424* 424* 424-RT	424* 424* 424-RT	624* 624* 624-RT	624* 624* 624-RT	624* 624* 624-RT
H	O-RING †	HVJ(P), HVS(P) HVB(P) HVSS(P) only	204* 204* 204-RT	204* 204* 204-RT	304* 304* 304-RT	404* 404* 404-RT	504* 504* 504-RT	604* 604* 604-RT	704* 704* 704-RT	804* 804* 804-RT
I	BODY	HVJ(P) HVB(P) HVS(P) HVSS(P)	100 100-B 100-S 100-SS	200 200-B 200-S 200-SS	300 300-B 300-S 300-SS	400 400-B 400-S 400-SS	500 500-B 500-S 500-SS	600 600-B 600-S 600-SS	700 700-B 700-S 700-SS	800 800-B 800-S 800-SS
J	SPRING †	ALL MODELS	207-**	207-**	307-**	407-**	507-**	607-**	707-**	807-**
K	PISTON †	HARDENED STEEL 416 STAINLESS STEEL 303 STAINLESS STEEL	206 206-A 206-SS	206 206-A 206-SS	306 306-A 306-SS	406 406-A 406-SS	506 506-A 506-SS	606 606-A 606-SS	706 706-A 706-SS	806 806-A 806-SS
L	STOP RING	HVJ(P), HVS(P) HVB(P) HVSS(P)	208-S 208-B 208-SS	208-S 208-B 208-SS	308-S 308-B 308-SS	408-S 408-B 408-SS	508-S 508-B 508-SS	608-S 608-B 608-SS	708-S 708-B 708-SS	808-S 808-B 808-SS
M	LOCK NUTS 2 REQ'D	HVJP, HVSP, HVBP HVSSP	505-S 505-S 505-SS	505-S 505-S 505-SS	605-S 605-S 605-SS	705-S 705-S 705-SS	705-S 705-S 705-SS	805-S 805-S 805-SS	745-S 745-S 745-SS	745-S 745-S 745-SS

* See o-ring selection chart
 ** See spring pressure chart
 † Recommended spare parts

DIMENSIONS

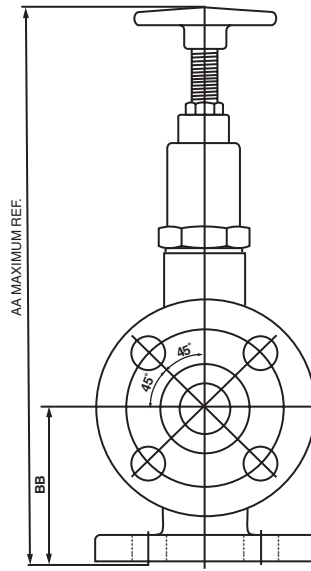
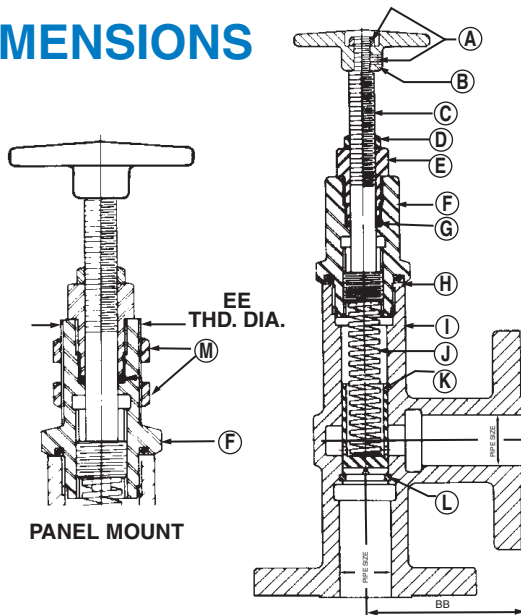

DIMENSIONS IN INCHES

Valve Size	AA	BB	EE
1"	13 ¹¹ / ₁₆	3 ¹ / ₂	1 ³ / ₈
1 ¹ / ₄ "	14 ¹¹ / ₁₆	3 ³ / ₄	1 ⁵ / ₈
1 ¹ / ₂ "	18 ⁷ / ₁₆	4 ¹ / ₁₆	2 ¹ / ₄
2"	18 ⁵ / ₈	4 ⁹ / ₁₆	2 ¹ / ₄

Note: Dimensions reflect 150# and 300# only

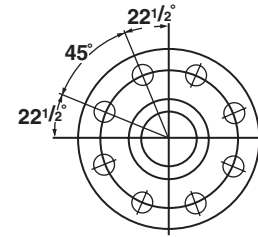

FOR 2" VALVE ONLY

PARTS LIST

SYM.	NAME	MODEL	DIMENSIONS IN INCHES			
			1"	1 ¹ / ₄ "	1 ¹ / ₂ "	2"
A	LOCK NUT OR SET SCREW	ALL MODELS	205-S	1/4"-20 COMM.	1/4"-20 COMM.	1/4"-20 COMM.
B	HANDWHEEL	ALL MODELS	429	629	629	629
C	ADJUSTING SCREW	HVJF(P) HVSF(P) HVBF(P) HVSSF(P)	522-S 522-B 522-SS	622-S 622-B 622-SS	722-S 722-B 722-SS	822-S 822-B 822-SS
D	LOCK NUT	HVJF(P), HVSF(P) HVBF(P) HVSSF(P) only	305-S 305-S 305-SS	655-S 655-S 655-SS	655-S 655-S 655-SS	655-S 655-S 655-SS
E	GLAND	HVJF(P), HVSF(P) HVBF(P) HVSSF(P)	525-S 525-B 525-SS	625-S 625-B 625-SS	725-S 725-B 725-SS	825-S 825-B 825-SS
F	BONNET	HVJF, HVSF HVBF HVSSF HVJPF, HVSPF HVBPF HVSSFP	523-SR 523-BR 523-SSR 528-SR 528-BR 528-SSR	623-SR 623-BR 623-SSR 628-SR 628-BR 628-SSR	723-SR 723-BR 723-SSR 728-SR 728-BR 728-SSR	823-SR 823-BR 823-SSR 828-SR 828-BR 828-SSR
G	O-RING †	HVJF(P), HVSF(P) HVBF(P) HVSSF(P) only	424* 424-* 424-RT	624* 624-* 624-RT	624* 624-* 624-RT	624* 624-* 624-RT
H	O-RING †	HVJF(P), HVSF(P) HVBF(P) HVSSF(P) only	504* 504-* 504-RT	604* 604-* 604-RT	704* 704-* 704-RT	804* 804-* 804-RT
I	BODY	HVJF(P) HVBF(P) HVSF(P) HVSSF(P)	500-F 500-BF 500-SF 500-SSF	600-F 600-BF 600-SF 600-SSF	700-F 700-BF 700-SF 700-SSF	800-F 800-BF 800-SF 800-SSF
J	SPRING †	ALL MODELS	507-**	607-**	707-**	807-**
K	PISTON †	HARDENED STEEL 416 STAINLESS STEEL 303 STAINLESS STEEL	506 506-A 506-SS	606 606-A 606-SS	706 706-A 706-SS	806 806-A 806-SS
L	STOP RING	HVJF(P), HVSF(P) HVBF(P) HVSSF(P)	508-S 508-B 508-SS	608-S 608-B 608-SS	708-S 708-B 708-SS	808-S 808-B 808-SS
M	LOCK NUTS 2 REQ'D	HVJFP, HVSPF, HVBFP HVSSFP	705-S 705-S 705-SS	805-S 805-S 805-SS	745-S 745-S 745-SS	745-S 745-S 745-SS

* See o-ring selection chart

** See spring pressure chart

† Recommended spare parts

V-SERIES PERFORMANCE CHARTS

All valve tests 110°F. to 120°F. Oil Viscosity 150 S.S.U. at 100°F.
(Charts good from 30 to 500 S.S.U.)

V-SERIES
VALVES

1/4" VALVE TESTS

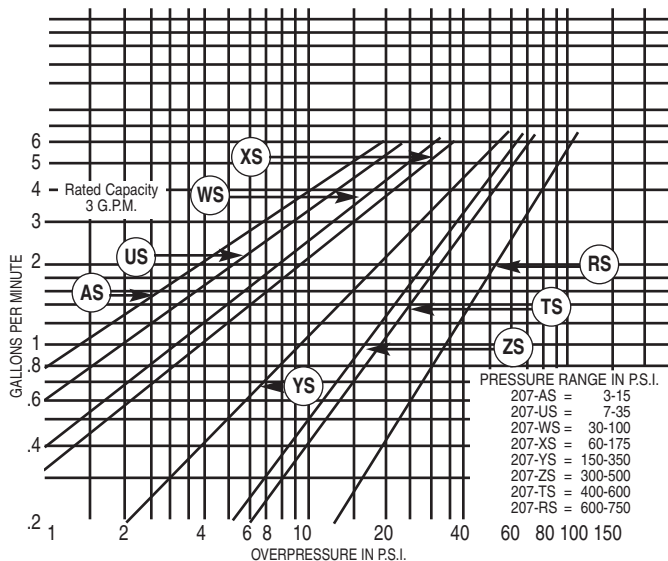

3/8" VALVE TESTS

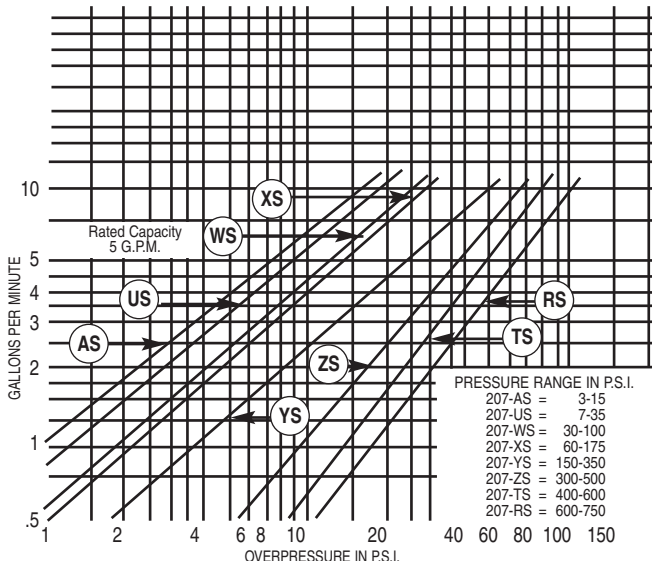

1/2" VALVE TESTS

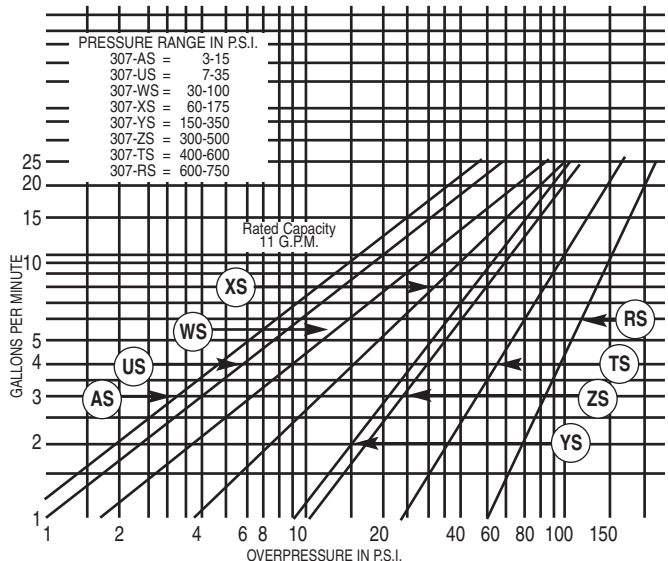

3/4" VALVE TESTS

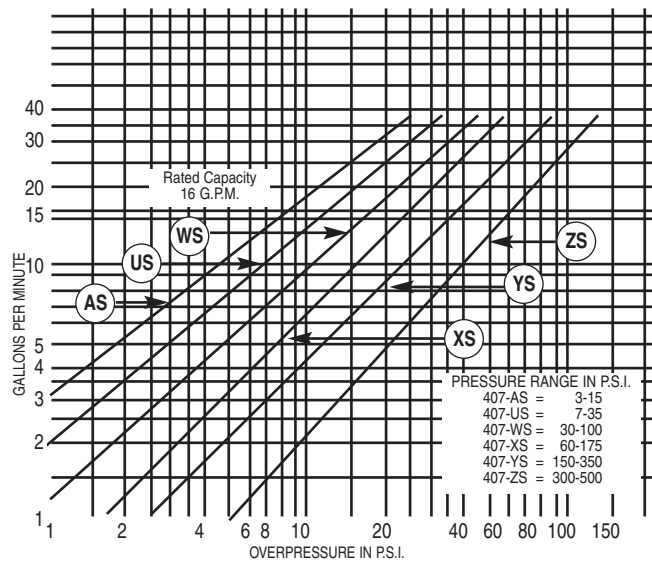

V-SERIES PERFORMANCE CHARTS

All valve tests 110°F. to 120°F. Oil Viscosity 150 S.S.U. at 100°F.
(Charts good from 30 to 500 S.S.U.)

1" VALVE TESTS

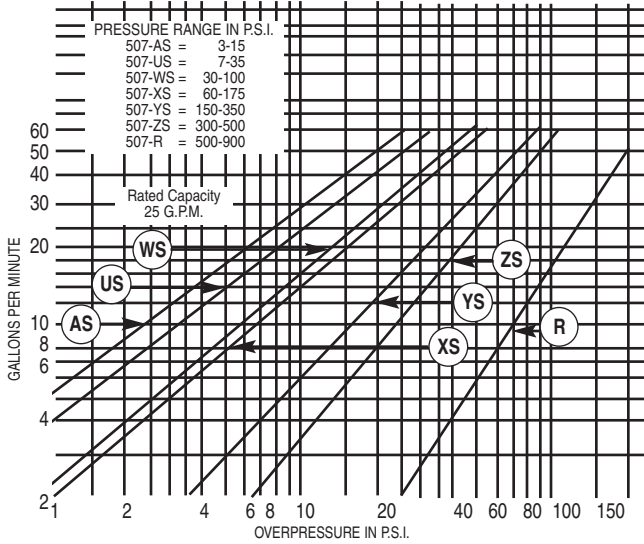

1 1/2" VALVE TESTS

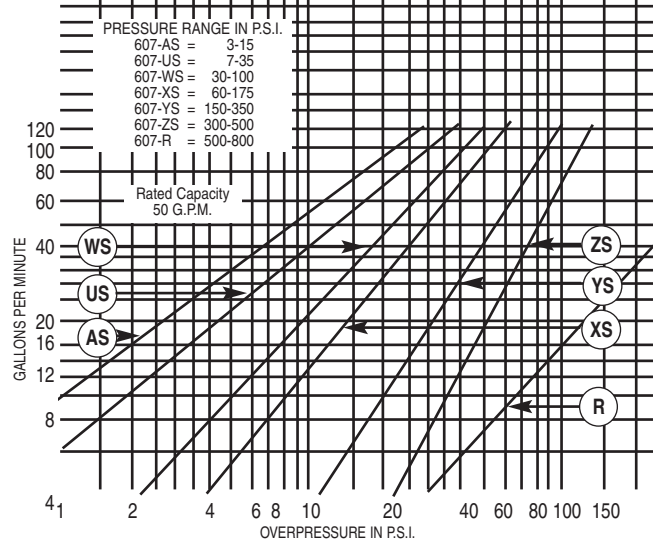

1 1/2" VALVE TESTS

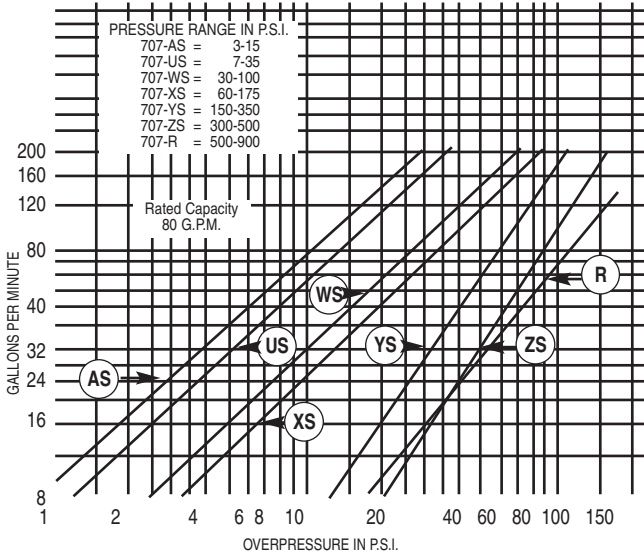

2" VALVE TESTS

