

BRONZE CLOSE COUPLED ROTARY GEAR PUMPS

GEAR PUMPS SERIES N999



FEATURES

- Rugged corrosion resistant bronze construction
- Compact close-coupled design
- Stainless steel shafts
- Durable bronze spur gears
- Process lubricated carbon graphite bearings
- O-ring cover seal for maximum leak protection
- Nitrile Lip Seal -standard
- Easy field assembly to a variety of motor frames
- For compact AC motor pump units - see Close Coupled Bronze Adapterless Rotary Gear Pumps
- For mechanical seal styles - see carbonator style - model N95060

DRIVE

Close coupled pumps are mounted directly to the electric motor by means of a suitable adapter bracket. The pump drive shaft is connected to the motor shaft by the flexible coupling.

LIQUIDS AND TEMPERATURE

These pumps are suitable for all liquids that are compatible with bronze. Most common liquids are water, oil, and mild chemicals in the pH range of 4 to 11. Viscous liquids require reduced shaft speeds of 1150 RPM or lower. (Consult factory.) Liquids containing solids, abrasives, powders, or paint pigments are definitely not recommended for gear pumps. If abrasives are unavoidable, use a very low shaft speed. The recommended liquid temperature range is from 32o F to 140o F for best pump life. If more extreme temperature conditions exist, factory should be consulted. Freezing of water-filled pumps can cause damage and must be avoided. Oils at low temperatures are very viscous requiring a lower speed or extra power.

PERFORMANCE

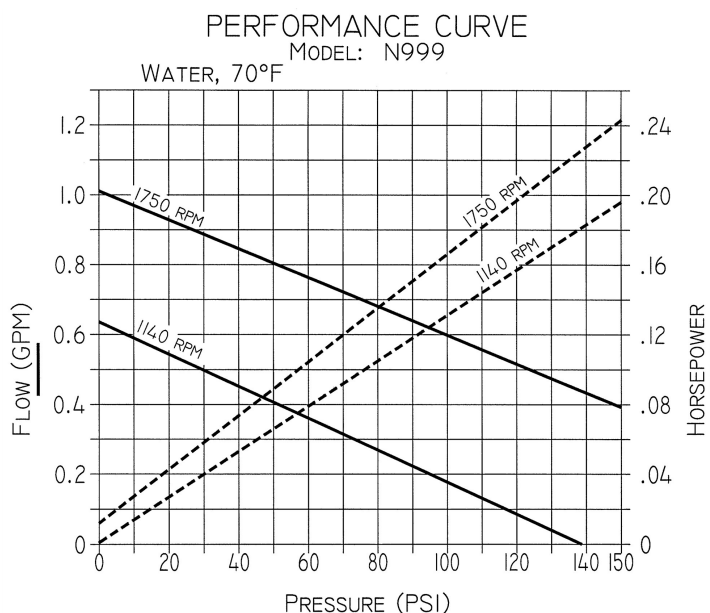

SUCTION LIFT

As a general rule, the suction lift should be kept at an absolute minimum by placing the pump as close to the liquid source as possible. A gear pump in new condition can lift 20 feet of water in the suction line. A foot valve (preferably with built-in strainer) is recommended at the beginning of the suction line. For a first start-up, the pump should be primed to avoid dry running. Minimum size of the suction pipe is the size of the pump inlet port. For longer suction lines (over 3 feet) or for viscous liquids, the pipe should be at least one size or two sizes larger than the pump inlet port.

EXPLODED VIEW AND PARTS LIST

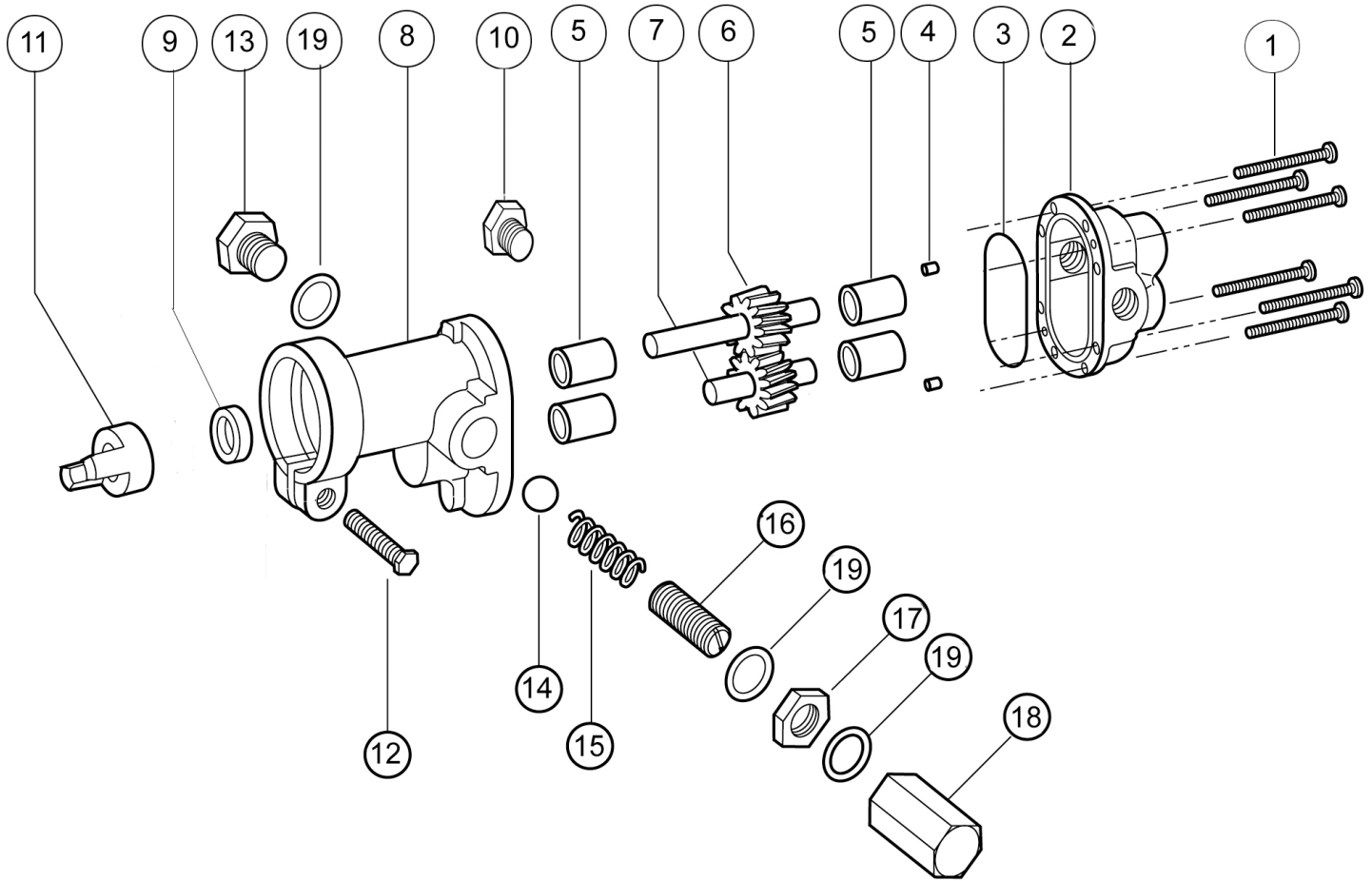

Pump No.	1	2	3 ²	4	5 ²	6 ²	7 ²	8	9 ^{1,2}	10	11	12	13	14	15	16	17	18	19
	Screw	Body	O-Ring	Dowel Pin	Bearing	Drive Gear Assy.	Idle Gear Assy.	Cover	Lip Seal	Cap Plug	Coupling	Screw	Plug Nut	Ball	Spring	Adj. Screw	Locknut	Bypass Nut	Fiber Washer
	6 Req'd	1 Req'd	1 Req'd	2 Req'd	1 Req'd	1 Req'd	1 Req'd	1 Req'd	1 Req'd	1 Req'd	1 Req'd	1 Req'd	1 Req'd	1 Req'd	1 Req'd	1 Req'd	1 Req'd	1 Req'd	3 Req'd
N999	5013	9302NB5N	9797-033	8885	5024	32198	32199	9303NN2N	5007	9346	5604	5595	---	---	---	---	---	---	---
N999R	5013	9302NB5N	9797-033	8885	5024	32198	32199	9303NN2B	5007	9346	5604	5595	1838	5803	1840	5237	5240	5239	6533

¹Seal # 5007 is Standard Buna N, # 7580 is Viton(R)*-Teflon(R)*

²Repair Kit contains items 3, 5, 6, 7 & 9. Repair Kit for N999(R) is #10873.

DIMENSIONS

N999(R)

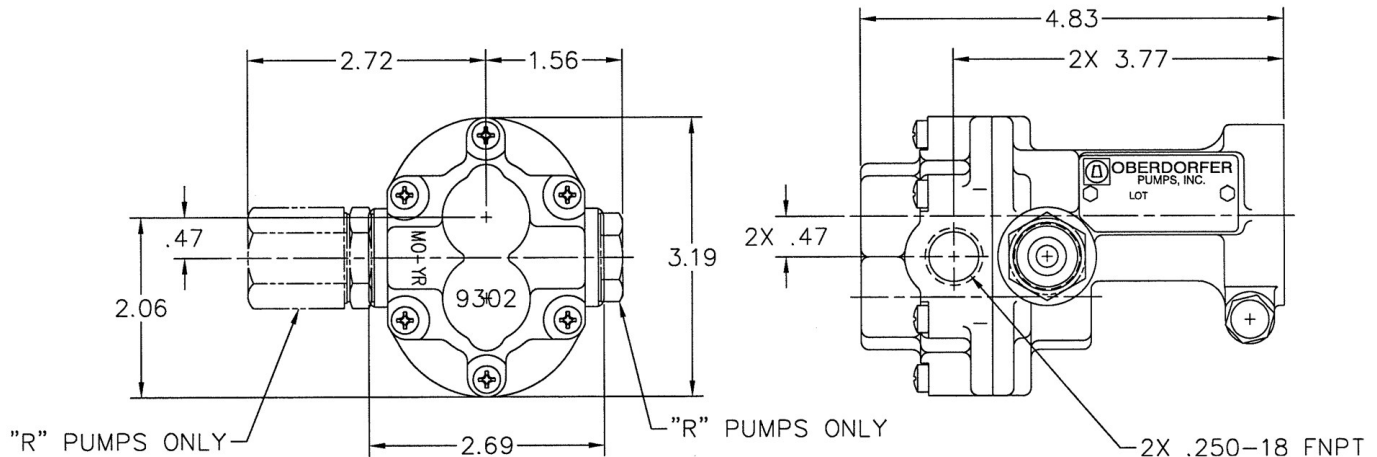

SHAFT SEALS

Close coupled gear pumps are normally supplied with a Nitrile lip seal. A lip seal made of fluoroelastomer is available as an option. For a fluoroelastomer Seal, add S5 to the pump model number.

OPTIONAL RELIEF VALVE

If the discharge line contains any throttling devices such as a shut-off valve, a spray nozzle or other restrictive device, it is necessary to have a relief valve in the system which returns the liquid to the suction side or to the tank. The relief valve is also available as part of the pump itself (R-model pumps). However, built-in relief valves are only good for intermittent service. If used continuously, the pump will overheat. A built-in relief valve is strictly a safety device against overpressure. It will not work successfully as a pressure or flow control device. For this purpose a separate relief valve in the pressure line must be used. Unless otherwise specified, the pump motor unit is supplied by the factory for shaft rotation counterclockwise from shaft end. Reversing motor will reverse "in and "out" ports and also requires changing relief valve location. The relief valve is always on the inlet side of this pump series. The factory pressure setting is 50 PSIG. To increase pressure, turn the relief valve adjusting screw in a clockwise direction.